



***Facility Study
For
Generation Interconnection
Request
GEN-2007-040***

SPP Tariff Studies

(#GEN-2007-040)

July 2010

Summary

Sunflower Electric Power Company (SUNC) performed the following Study at the request of the Southwest Power Pool (SPP) for Generation Interconnection request Gen-2007-040. The request for interconnection was placed with SPP in accordance SPP's Open Access Transmission Tariff, which covers new generation interconnections on SPP's transmission system.

Pursuant to the tariff, SUNC was asked to perform a detailed Facility Study of the generation interconnection request to satisfy the Facility Study Agreement executed by the requesting customer and SPP.

Interconnection Customer Interconnection Facilities

The Interconnection Customer will be responsible for the 345 kV transmission line from the point of interconnection to its 345/34.5 kV substation that will contain its 345/34.5 kV transformer(s) and wind turbine collector feeders. In addition, the Customer will be required to maintain a power factor from 0.976 lagging to 0.956 leading at the point of interconnection (a new SUNC 345 kV switching station on the Holcomb-Spearville 345 kV transmission line).

Transmission Owner Interconnection Facilities and Non Shared Network Upgrades

Per the following Facility Study, the Interconnection Customer is responsible for \$10,404,019 of Transmission Owner Interconnection Facilities and non-shared network upgrades.

DISIS-2009-001 Shared Network Upgrades

The interconnection customer was studied within the DISIS-2009-001 Impact Study. At this time, the Interconnection Customer is allocated \$0 of shared network upgrades. If higher queued interconnection customers withdraw from the queue, suspend or terminate their LGIA, restudies will have to be conducted to determine the Interconnection Customers' allocation of shared network upgrades. All studies have been conducted on the basis of higher queued interconnection requests and the upgrades associated with those higher queued interconnection requests being placed in service.

Executive Summary

<OMITTED TEXT> (Customer) has requested a Facility Study under the Southwest Power Pool Open Access Transmission Tariff (OATT) for interconnecting a 200.1 MW wind powered generation facility in Gray County, Kansas to the transmission system of Sunflower Electric Power Company (SUNC). The wind powered generation facility studied was proposed to comprise of eighty-seven (87) Siemens SWT 2.3 MW wind turbines. The wind powered generation facility will interconnect into a new 345 kV switching station on the Holcomb-Spearville 345 kV transmission line.

SUNC will build a new 345 kV ring-bus switching station and terminate Gen-2007-040 wind farm. The Interconnection Customer's non shared network upgrades and interconnection facilities are estimated at \$10,404,019.

The Customer will have certain facility requirements in its substation to interconnect the generation facility. The Customer will be required to maintain a power factor from 0.976 lagging to 0.956 leading at the point of interconnection.

1. Introduction

<OMITTED TEXT> (Customer) has requested a Facility Study under the Southwest Power Pool Open Access Transmission Tariff (OATT) for interconnecting a 200.1 MW wind powered generation facility in Gray County, Kansas to the transmission system of Sunflower Electric Power Company (SUNC). The wind powered generation facility studied was proposed to comprise of eighty-seven (87) Siemens SWT 2.3 MW wind turbines. The wind powered generation facility will interconnect into a new 345 kV switching station on the Holcomb-Spearville 345 kV transmission line.

2. Interconnection Facilities and Network Upgrades

The cost for the Interconnection Facilities and Network Upgrades is listed below in Table 1. The one-line diagram is shown in Figure 1.

Table 1: Required Interconnection Facilities and Non Shared Network Upgrades

Project	Description	Estimated Cost
1	SUNC-Build 345 kV ring-bus switching station and terminate GEN-2007-040 wind farm.	\$10,404,019
	Total:	\$10,404,019

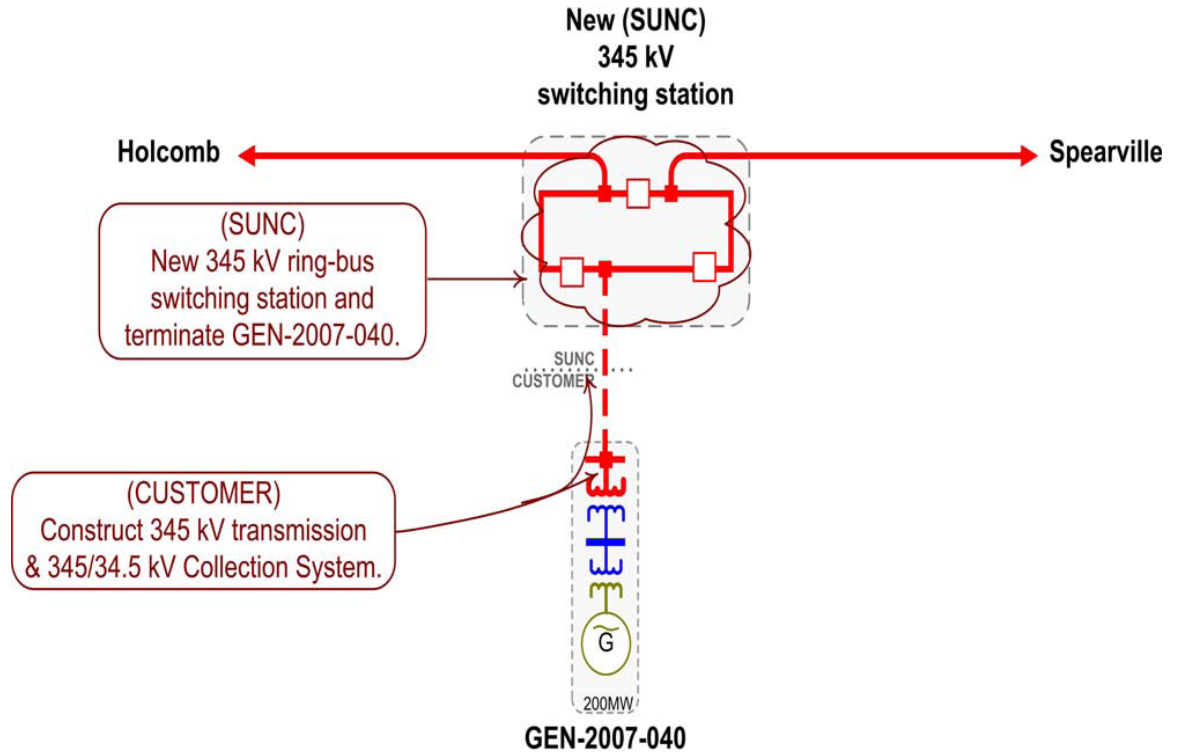

Figure 1. Interconnection Configuration for GEN-2007-040

2.1. Customer Facilities – The Customer will be responsible for its Generating Facility and its 345/34.5 kV substation that will contain its 345/34.5 kV transformer(s) and wind turbine collector feeders. In addition, the Customer will be required to install the following equipment in its facilities.

2.1.1. Reactive Power Equipment – Per the Impact Study, the Interconnection Customer may be required to install capacitor banks as necessary in addition to the studied Siemens 2.3 MW wind turbines to maintain the required 0.976 lagging to 0.956 leading power factor at the point of interconnection.

3. Conclusion

The Interconnection Customer's interconnection facilities are estimated at \$10,404,019.